

Influence of different focus of attention instructions on learning volleyball skills for young novices

AFRODITI LOLA , ANDRIANI KOUTSOMARKOU, GEORGE TZETZIS

Department of Physical Education and Sport Science, Aristotle University of Thessaloniki, Greece

ABSTRACT

The simultaneous improvement of both form and outcome of sport skills is a challenge for every instructor since these are competing goals, especially for novices, and in the early stages of learning the improvement of movement form is usually more important than outcome. However, when novices have both goals, outcome usually prevails over form. External over internal focus of attention has been proposed by many researchers as an effective method for the development and learning of movement form or outcome. In this study, 57 girls were randomly divided into 2 experimental groups (external and internal) and a control group. All groups performed a pre-test. The two experimental groups followed an intervention program for 12 training units (6 weeks X 2 times a week). A post-test and a transfer test followed two weeks later. Data were analysed by factorial ANOVA (3 groups X 3 measurements) with repeated measurements of the last factor, followed by a post-hoc Tukey test. Both experimental groups, but not the control group, improved their performance in both form and outcome from pre-test to post-test and transfer test. The external focus group scored better in both form and outcome than the internal focus group in the post and transfer tests. It seems that external focus drives a subconscious motor control that results in greater movement automaticity and improves both form and outcome of sport skills. It is concluded that the external focus method is appropriate to develop both form and outcome of perceptual-motor skills.

Keywords: Motor development; External instructions; Internal instructions; Motor performance.

Cite this article as:

Lola, A., Koutsomarkou, A., & Tzetzis, G. (2022). Influence of different focus of attention instructions on learning volleyball skills for young novices. *Journal of Human Sport and Exercise*, 17(4), 867-881. <https://doi.org/10.14198/jhse.2022.174.14>

 **Corresponding author.** *Department of Physical Education and Sport Science, Aristotle University of Thessaloniki, Thessaloniki, 54124. Greece.*

E-mail: afroditelola@yahoo.gr

Submitted for publication December 02, 2020

Accepted for publication February 09, 2021

Published October 01, 2022 (*in press* March 09, 2021). Results updated October 08, 2021.

JOURNAL OF HUMAN SPORT & EXERCISE ISSN 1988-5202

© Faculty of Education. University of Alicante

doi:10.14198/jhse.2022.174.14

INTRODUCTION

The simultaneous improvement of both form and outcome of sport skills is a challenge for every instructor. It is very important for novices to acquire the movement form of a new skill first, and then improve the movement outcome (Haibach et al., 2011). Since these are competing goals, especially in the early stages of learning, the improvement of movement form is usually more important than the outcome. However, when novices have both goals, the outcome goal usually prevails over the form goal (Haibach et al., 2011).

Several studies have demonstrated that manipulation of feedback instructions that induce an external focus by directing performers' attention to the effects of their movements (external focus) rather than their body movements (internal focus) result in more effective motor performance and learning for either movement form or outcome (Lohse et al., 2012). The external focus provides a subconscious motor control that results in greater movement automaticity, compared to the internal focus of attention (Wulf et al., 1998; Wulf, 2007; Wulf & Lewthwaite, 2010; Wulf, 2013; Graaff et al., 2018). Chua and colleagues (2019) mention that training via external focus leads on automatic control processes (Wulf, McNevin & Shea, 2001; Wulf, Shea, & Park, 2001) and frees up that system to engage flexible, reflexive movement control processes, and likely enhances functional connectivity of task-relevant brain areas (Wulf & Lewthwaite, 2016). Chua et al. (2019) also note that internal focus is linked with self-related thoughts and increases micromanagement of the intended movement such that learners are more likely to engage in conscious control of their motor system and disrupt automaticity (Wulf & Lewthwaite, 2010, 2016). The theoretical background can be explained by the "Constrained Action Hypothesis" (Wulf, McNevin, & Shea 2001): when body movements are controlled consciously (internal focus), this seems to interrupt the automated control, thereby improving plasticity and ultimately effectiveness. In contrast, the use of an external focus provides a subconscious motor control that enhances movement automaticity.

Although there have been many studies evaluating the effect of different focus of attention on either movement form or outcome, very few have measured the effect of both form and outcome simultaneously, on the field, using young novices. Wulf (2013) in her review reported that most of the studies assess effects on performance rather than learning. Most researchers (Denny, 2010; Lawrence et al., 2010; Tsetseli et al., 2016; Niżnikowski et al., 2016) have traditionally used a post-test or retention-test in their experimental design, while very few evaluated the effectiveness of training methods in different parameters (Emanuel et al., 2008; Lawrence et al., 2010). In the present study a performance test and a transfer of learning test were used, since in many sports with open skills, such as volleyball, the goal is to adjust the skill in a changing sport environment. In volleyball, it is very important for children to adjust their skills in different parameters (distance, direction, trajectory, etc.).

In Wulf's (2013) review of the literature on the effectiveness of attentional focus, several limitations were reported in the evaluation of the movement pattern, using direct laboratory measures such as muscular activity (electromyographic or EMG), oxygen consumption, heart rate, etc., or indirect laboratory measures such as maximum force production, movement speed, or endurance. Kinematic measures quantify the spatial and temporal properties of movements of multiple body parts simultaneously. However, open perceptual-motor skills, such as volleyball passing, require cognitive processes in order to achieve the optimal movement form and outcome. Similarly, there are many findings on the influence of different attentional focus on movement outcome (Singh, & Wulf, 2020; Abdollahipour et al., 2017; Wulf & Su, 2007; Lohse et al., 2014; Marchant et al., 2009), measured in the laboratory through muscular activity, maximum force production, speed, or endurance. Thus, the above direct and indirect evaluation criteria of movement form may not be

appropriate to open perceptual-motor skills. In the present study, the form and the movement outcome were tested simultaneously using subjective rating measures, in the field, which is more realistic.

Researchers in the field of skills acquisition examining the effect of external versus internal focus of attention have mainly used adults as participants (Makaruk et al., 2020; Yamada et al., 2020; Agar et al., 2016). However, it must be determined to what extent their conclusions apply to children (Roshandel et al., 2017). There are few studies examining the effect of these methods on children of 9-10 years of age (Emanuel et al., 2008b; Wulf et al., 2010), while there is no research if any on the effectiveness of these methods in girls aged 9-10 years in volleyball passing. Despite the consistent evidence in favour of the hypothesis that external focus is superior to internal focus in adults, research on the benefits of internal and external focus of attention in children is ambiguous (van Abswoude et al. 2018). While some studies have confirmed the beneficial effects of external focus on children (Abdollahipour et al., 2017; Brocken et al., 2016; Flôres et al., 2015; Hadler et al., 2014), others showed that the focusing function had no effect on children's motor learning and performance (Emanuel et al., 2008; Perreault & French, 2016). Despite the extensive literature and the strong finding that the external focus of attention facilitates motor learning in a variety of skills, there is still a significant limitation. Most of these studies are limited to adult populations (Singh & Wulf, 2020; Denny, 2010; Hill et al., 2018); there is some research in child populations on motor tasks such as bowling tasks (Abdollahipour et al., 2017), throwing beanbags (Chiviawosky et al., 2013), hitting tennis balls (Hadler et al., 2014), or shooting basketballs (Perreault & French, 2015), but there is no research on novice girls aged 9-10 years in volleyball passing. Conflicting findings demonstrate that age (Emanuel et al., 2008), skill level (Wulf, 2008), gender (Wulf et al., 2003), and individual preferences (Wulf, Shea, & Park, 2001) may have a crucial effect on the evaluation of training methods in perceptual-motor skill performance. However, the most effective method of focusing children's attention (Perreault & French, 2016) in open perceptual-motor skills is not yet fully understood.

The aim of this study was to examine the effectiveness of the two methods of focusing attention (internal and external focus) in the acquisition and transfer of learning by comparing them with a control group, in terms of movement form and outcome. This study brings together some advantages and addresses some limitations of past studies, such as: a) the study participants were children (9-10 years) and beginners in volleyball; b) the evaluation was implemented in real field conditions (field study); c) movement form and outcome were evaluated simultaneously; d) the effectiveness of training methods was examined in different parameters (transfer test); e) participation of a control group; and f) evaluation of one open perceptual-motor skill (volleyball passing) in a changing environment. The authors of the present study hypothesized that the external focus of attention training method would be more effective than internal focus in terms of both movement form and outcome, for novice participants in transfer conditions.

MATERIAL AND METHODS

Participants

The study involved 57 girls aged 9 to 10 years ($M = 9.3$, $SD = 0.2$), who were randomly selected and classified into 3 groups of 19 girls (two experimental and one control group). The experimental groups consisted of: a) 19 girls in the internal group (attention is focused on the movement), b) 19 girls in the external group (attention is focused on the effects of the movement in the environment), and c) 19 girls in the control group, which only participated in the tests. They were evaluated on the volleyball passing skill (object manipulation skill), in terms of both movement form and outcome. Their participation in the study was voluntary and with the consent of the parents and instructors. Prior to the study, the instructors agreed not to further practice the skills to be examined (passing) during the intervention, so as not to affect the results of the study.

Measures

Evaluation of volleyball passing in terms of both movement form and outcome (pre-test and post-test)

Each participant made 23 frontal passing attempts (the first 3 attempts done in order to understand the test) from the passer's position, along the net, to the front of zone 4. After the 23 attempts, the next participant took a position until she made all the attempts. Both movement form and outcome were evaluated at the same time. The same procedure was also used in the pre-test and post-test. According to the evaluation of the movement form (AAHPER, 1969), 3 points (assessment criteria) were considered while the participant passed the ball: a) legs, b) torso, and c) frontal gaze. If the participant had 1 of the 3 points correctly placed, the score was 1, if the participant had 2 of the 3 points correctly placed, the score was 2, and if the participant had all 3 points correctly placed, the score was 3. In order to achieve the optimal movement form, participants had to score 3/3. According to the evaluation of the movement outcome (Wulf et al., 2002), 3 points were considered as the following score: a) 1.5m line = 1 point, b) 2m line = 2 points, c) 2.5m line = 3 points. In order to achieve the optimal movement outcome, the participants had to send the ball to the 2.5m line = 3 points (Figure 1). No feedback was given to the participants during the test. Two independent judges evaluated both movement form and outcome. Before the participants started the test, the researchers described the test, the purpose and the evaluation method to them in detail, and then a former professional volleyball player executed the task.

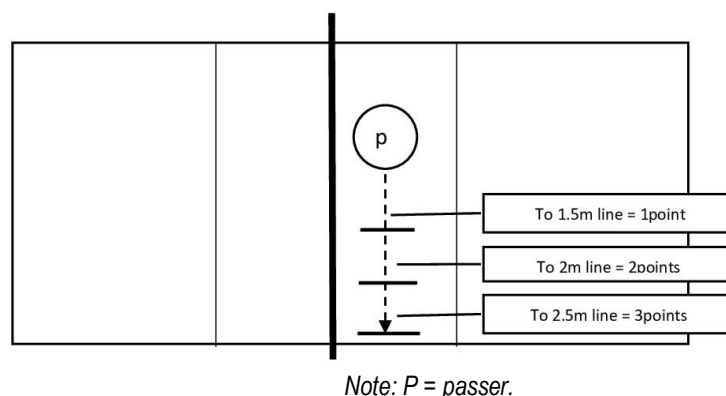

Figure 1. Evaluation of volleyball passing in terms of movement outcome (pre-test and post-test).

Evaluation of volleyball passing in terms of both movement form and outcome (transfer test)

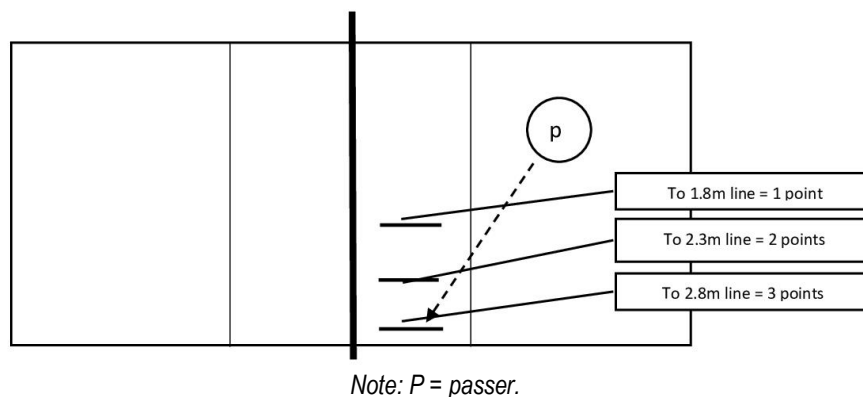

Figure 2. Evaluation of volleyball passing in terms of movement outcome (transfer test).

Two weeks after the post-test, without further practice, a transfer test was implemented with different parameters (different direction of passing, and different trajectory lengths), in order to evaluate the transfer of learning in the long run and in different conditions. The track lengths were increased by 0.3 m distance, to 1.8m, 2.3m, and 2.8 m. Regarding the direction of the ball, the participant passed from position 1 to position 4 (Figure 2). Before the participants started the test, the researchers described the test, the purpose and the evaluation method to them in detail, and then a former professional volleyball player executed the task.

Procedure

On the first day of the meeting, the researchers informed the participants, their instructors and their parents about the process and its purpose and assured them that they could leave at any time during the process, and that their personal data would be protected. The participants were randomly divided into 3 groups (external, internal, and control) and performed the pre-test on the field. The purpose of the pre-test was to make sure that all participants had the same level in passing skill, in terms of both movement form and outcome. After the pre-test came the intervention program, according to two different training methods for the development of volleyball passing. The duration of the program was 12 workouts over 6 weeks (2 times / week). The total duration of each training unit was 60-70 minutes. Only the experimental groups (internal and external group) participated in the intervention program. After the intervention program was completed, a post-test was implemented to show the effectiveness of the two training methods. Two weeks after the end of the program, without further practice, a transfer test was implemented in order to evaluate the effectiveness of learning in different parameters.

Intervention program

All groups, except the control group, participated in the intervention program which included theoretical and practical phases via different focusing instructions (internal or external). The intervention program had a total duration of 6 weeks with 2 training units per week (12 units). Each training unit lasted 60-70 minutes. Initially, the girls watched a 10-minute video (theoretical phase) of elite athletes passing in real matches. The instructors highlighted the crucial points in the video in a different way in each group. For the internal learners, the key points on the body of the elite players were highlighted. For the external learners, the target, the trajectory of the ball, etc. were highlighted. Then the girls participated in a 10-minute warm-up on the court and continued with 20 minutes practicing passing (practical phase). During practice, the group that practiced via internal focus of attention received five (5) rules which focused on the body parts (key points) for the effective performance of the motor skill (both movement form and outcome). The group that practiced via external focus of attention received five (5) rules which focused on the target, the trajectory of the ball, etc.

Analysis

Independent variables were: a) the “*group*”, consisting of three (3) levels: i) internal focus, ii) external focus and iii) the control group, and b) the “*measurement*”, consisting of three (3) levels: i) the pre-test, ii) the post-test and iii) the transfer test. Dependent variables were the performance in the motor skill of volleyball passing, in: a) the movement form (score), and b) the movement outcome (score).

A two-way factorial analysis of variance (ANOVA 3 group x 3 measurement) with repeated measurement of the last factor was conducted, and a post-hoc Tukey test was used to analyse significant differences ($p < .05$).

RESULTS

Evaluation of volleyball passing in terms of movement form

There was a statistically significant main effect ($F_{(1.116, 60.26)} = 76.5196, p < .001$) among the three measurement periods. More specifically, during the pre-test the three groups (external, internal, and control) did not show any statistically significant differences. The external group improved its performance from the pre-test to the post-test and remained constant during the transfer test. The internal group improved its performance from the pre-test to the post-test and maintained its performance during the transfer test. In the control group, there were no statistically significant differences from the pre-test to the post-test and transfer test.

There was a statistically significant main effect ($F_{(2.54)} = 22.980, p < .001$) among the three groups. In the post-test the external group had better mean scores than the internal group, while the internal group had better mean scores than the control group. In the transfer test, the external focus group had better mean scores than the internal focus group, which in turn was better than the control group. There was a statistically significant interaction ($F_{(2.232, 60.26)} = 19.744, p < .001$) among the three measurement periods and the three groups. The results are summarized in the table below (Table 1).

Table 1. Analysis of variance among groups, among measurements, and their interaction (movement form).

	SS	df	MS	F	p	η^2
Test	2.945	1.116	2.639	76.196	<.001	0.585
Group	4.995	2	2.498	22.980	<.001	0.460
Test * Group	1.526	2.232	0.684	19.744	<.001	0.422

*Mauchly's $W = 0.208, p < .001, G-G = 0.558 < 0.75, Greenhouse-Geisser Correction utilized.$

In order to examine further differences, a post-hoc Tukey analysis was conducted, with results shown in the table below (Table 2).

Table 2. Post-hoc tests in passing scores (movement form), among the three groups that practiced with different training methods and among the three tests.

	External (ex)		Internal (in)		Control (co)		Post hoc*
	M	SD	M	SD	M	SD	
Pre-test (Pre)	1.742	0.215	1.750	0.157	1.650	0.233	ex = in = co
Post-test (Post)	2.292	0.246	2.016	0.238	1.703	0.217	ex > in > co
Transfer test (T)	2.263	0.258	1.984	0.221	1.692	0.192	ex > in > co
Post hoc**	Pre<Post, Post=T		Pre<Post, Post=T		Pre=Post, Post=T		

*One-Way Anova with Tukey Post Hoc, $p < .05$. **Friedman's Two-Way Analysis of Variance by Ranks with Bonferroni Correction Post Hoc, $p < .05$.

The following figure shows the curves of the averages in passing scores (movement form), among the three groups that practiced with different training methods and among the three tests (Figure 3).

Evaluation of volleyball passing in terms of movement outcome

There was a statistically significant main effect ($F_{(1.272, 68.679)} = 117.111, p < .001$) among the three measurement periods. More specifically, during the pre-test the three groups (external, internal, and control) did not show any significant differences. The external group improved its performance from the pre-test to the post-test and remained constant during the transfer test. The internal group improved its performance

from the pre-test to the post-test and maintained its performance during the transfer test. In the control group, there were no statistically significant differences from the pre-test to the post-test and transfer test.

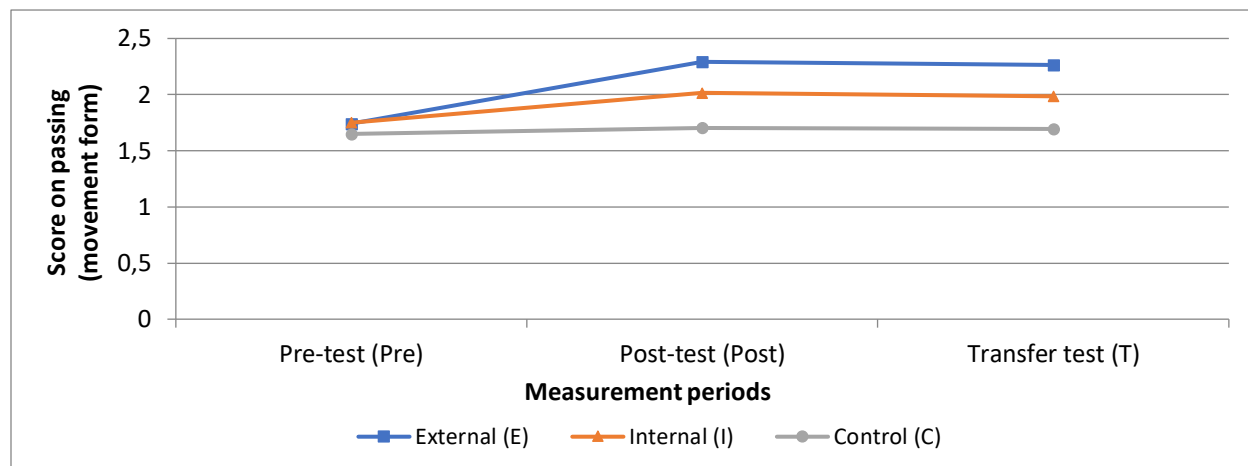

Figure 3. Mean scores in passing movement form, among the three groups that practiced with different training methods and among the three tests.

There was a statistically significant main effect ($F_{(2,54)} = 38.042, p < .001$) among the three groups. In the post-test, the external group had better mean scores than the internal group, while the internal group had better mean scores than the control group. In the transfer test, the external focus group had better mean scores than the internal focus group, which in turn was better than the control group. There was a statistically significant interaction ($F_{(2,544, 68.679)} = 38.921, p < .001$) among the three measurement periods and the three groups. The results are summarized in the table below (Table 3).

Table 3. Analysis of variance among groups, among measurements, and their interaction (movement outcome).

	SS	Df	MS	F	p	η^2
Test	3.543	1.272	2.786	117.111	<.001	0.684
Group	6.997	2	3.498	38.042	<.001	0.585
Test * Group	2.355	2.544	0.926	38.921	<.001	0.590

*Mauchly's $W = 0.427, p < .001, G-G = 0.636 < 0.75, Greenhouse-Geisser Correction utilized.$

In order to examine further differences, a post-hoc Tukey analysis was conducted, with results shown in the table below (Table 4).

Table 4. Post-hoc tests in passing scores (movement outcome), among the three groups that practiced with different training methods and among the three tests.

	External (ex)		Internal (in)		Control (co)		Post hoc*
	M	SD	M	SD	M	SD	
Pre-test (Pre)	1.897	0.126	1.821	0.163	1.808	0.228	ex = in = co
Post-test (Post)	2.547	0.216	2.134	0.160	1.818	0.247	ex > in > co
Transfer test (T)	2.463	0.258	2.108	0.164	1.800	0.214	ex > in > co
Post hoc**	Pre<Post, Post=T		Pre<Post, Post=T		Pre=Post, Post=T		

*One-Way Anova with Tukey Post Hoc, $p < .05$. **Friedman's Two-Way Analysis of Variance by Ranks with Bonferroni Correction Post Hoc, $p < .05$.

The following figure shows the curves of the averages in passing scores (movement outcome) among the three groups that practiced with different training methods and among the three tests (Figure 4).

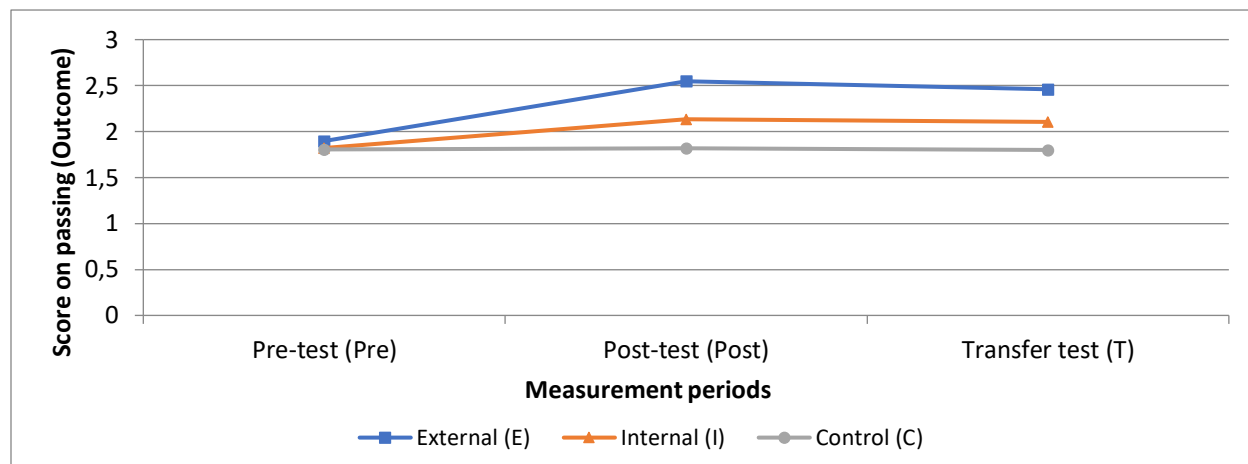

Figure 4. Mean scores in passing movement outcome, among the three groups that practiced with different training methods and among the three tests.

DISCUSSION AND CONCLUSIONS

The main purpose of this study was to examine whether previous findings on the learning advantages of external compared to internal-focus feedback (Wulf, 2013) would generalize to open perceptual-motor sport skills, such as volleyball passing. In addition, it was examined whether there would be differential effects of the attentional focus on movement form and outcome when these two criteria were measured simultaneously, and in different parameters (transfer test) for novice participants.

The results of the study showed that external-focus feedback resulted in more effective performance than internal-focus feedback in terms of the movement outcome and form of the volleyball passing for novice participants. This type of attentional focus improved both movement form and outcome during the acquisition, and also in the transfer test 2 weeks after the post-test with no feedback. It is very interesting that, even for the external focus group, the participants did not need the explicit rules to improve their movement form in both the post and transfer test. Similar results were found in a more recent study by Tsetseli and colleagues (2018), who found better scores in tennis serving movement form by young athletes who practiced using external focus of attention than in those who practiced using internal focus. They argue that in studies with more stable (closed) environments, no differences were found between the internal and external attentional focus group, in movements such as golf shot (Wulf et al., 2003) and soccer kick from a fixed ball position (Uehara et al., 2008). This may lead to the conclusion that instructions directing the attention externally may be more effective and beneficial for open skills (Castaneda & Gray 2007; Tsetseli et al. 2018).

Regarding the movement outcome, it was found that the external focus group performed better than the internal focus group. It seems that the motor learning process can be accelerated by directing one's attention externally to the desired movement. This is also proposed by the "Constrained Action Hypothesis" (Wulf, McNevin & Shea, 2001), which suggests that an external focus of attention promotes a more automatic type of control and allows the motion system to take advantage of unconscious and rapid control processes. Instead, an internal focus may lead to a conscious type of control, causing learners to restrict their motor

system by interfering with automated procedures (Abdollahipour et al., 2017). Poolton and colleagues (2006) also suggest that external attention cues, even during the initial stage of learning, reduce the load of working memory. In contrast, internal attention cues increase the load of working memory, which may lead to reduced performance, especially in young individuals. The external learners in our study probably executed the movements without memory overloading, which provides learners with greater resources in order to carry out more complex tasks (Lola & Tzetzis, 2020).

Another explanation for the superiority of external over internal focus of attention is provided by the “*Optimal Theory*” (Wulf & Lewthwaite, 2016), in which external attentional focus conditions are presumed to facilitate functional connectivity, that is, task-specific neural connections across distinct brain regions that are seen in skilled performers. Lack of a clear task focus (internal focus) would impede switching to task-related functional networks or goal-action coupling (Ghorbani, 2019). Wulf and Lewthwaite (2016) also suggest that adopting an external focus of attention leads to the promotion of learners’ focus on the goal, and that this directly connects goals and actions, strengthening the goal-action coupling. It seems that external focus of attention contributes significantly to the goal-action connection. By directing the concentration away from the body and to the desired effect of the movement or the target, external focus favours the establishment of effective neural connections that are critical for optimal performance. The result is an effective movement pattern and improved learning and performance. The results of the present study also agree with the research of Ghorbani and colleagues (2019), which showed support for the “*Optimal Theory*” and proposed that the adoption of an external focus of attention directs the attention on target, successfully and perhaps more beneficially to young athletes (Abdollahipour & Psotta, 2017). Moreover, it is well established that external focus enhances neuromuscular automaticity, increases task goal orientation (Wulf & Lewthwaite, 2016), reduces cognitive load (Kal et al., 2013), and alleviates performance anxiety (Abdollahipour et al., 2017). Similar results were found by Tsetseli and colleagues (2018) with a tennis serve skill.

Marchant and colleagues (2009), and Abdollahipour and colleagues (2008) found no differences between external and internal focus groups on the outcome of closed skills; however, they measured the precision and speed of the movement, which is different to the measurement of movement form and outcome in the present study. Wulf and colleagues (2002), in a similar study on high school and university students learning the volleyball “*tennis serve*”, found that the external focus group was better than the internal focus group during the acquisition phase, but no differences were found during the retention phase, indicating that the deduction of feedback during retention might have detrimental effects on the internal focus group. In our present study on young (9-10 years) novices, it seems that the deduction of feedback during the transfer test did not have detrimental effects on the internal or the external focus groups. The different results to those of Wulf’s (2002) study may be attributed to the different age of the participants, and the different evaluation method (laboratory vs field test and transfer vs retention test). Thus, it can be concluded that the provision of external attentional focus instructions is more beneficial when what is assessed is the skill technique, as in our study, rather than the precision and speed of the movement.

It is also important to note that both groups (internal and external focus) did improve with practice. The internal group also improved its performance on both movement form and outcome from the pre-test to the post-test, while it maintained its performance during the transfer test; however, it had lower scores than the external focus group. The improvement of the internal focus group was probably due to the fact that the explicit instructions in the body (internal focus of attention) led to the formation of conscious, verbalizable bits of knowledge that were manipulated in working memory to support the response (Lola et al., 2012). However, the scores of the internal focus group on movement form and outcome, were lower than those of the external focus group. This can be probably explained by the fact that the internal focus group participants were

thinking too much about the rules in order to respond and engaging in conscious thought processes that could interfere with the automatic process of the response (Lola et al., 2012). The argument that internal focus of attention is necessary and beneficial in early learning is often supported by findings showing that beginners perform better when their attention is focused on skill (Wulf, 2013; Agar et al., 2016). Internal focus learners improved their performance over time via the development of declarative, followed by procedural knowledge, using the internal instructions. According to Masters (1992), during a motor execution, declarative knowledge of “*what to do*” is usually acquired in early learning stages, when the individuals try to find which response is the most optimal. Cognitive knowledge and conscious processing regarding the components of motor skills have been found to produce poor performance (Beilock & Carr, 2001; Masters, 1992). It seems that the internal learners tried to consciously recall the rules governing the answer, and therefore tended to consciously interfere with the control processes and interrupt the automatic response processes.

Since both methods improve movement form and outcome, the decision of where to focus may not be a matter of what is right or wrong, but rather which is better under certain circumstances (Denny, 2010). Instructors should consider that effective sport skill learning occurs using either an internal or external attention focus depending on various factors, including whether the skill is open or closed, as well as the preferred attention focus of the participant (Denny, 2010). In the present study the results covered both movement outcome and form, measured simultaneously while simulating real volleyball passing conditions using a transfer test, since for an open skill (volleyball passing) the learner needs to learn a multitude of variations on the movement in order to adjust the performance to an unpredictable and changing environment (Haibach et al., 2011). In conclusion, the results of the present study suggest that adopting an external focus of attention in learning a motor handling skill, such as volleyball passing, in 9-10 year-old girls, helps to improve the performance of the skill more than internal focus of attention does. The adoption of an external focus of attention led to the enhancement of motor learning and performance, and promoted participants' focus on the goal, as opposed to an internal focus of attention. It is worth highlighting here that directing attention to the task goal (hitting the target) bridges the gap between goal and action (Makaruk et al., 2020).

Implications

The present findings have important practical applications, as they will be extremely useful to instructors training novice girls in simple open skills. Based on the results of the present study, it is proposed that instructors direct performers' attention not to their body movement but to the outcome, in order to improve both form and outcome. This finding is different to the traditional approach, in which the focus of attention is the practitioner's body movements (Wulf, 2012). It was also observed empirically that the children who participated in the external group were more enthusiastic and appeared more confident.

Future research

In future research exploring attention preferences to determine if an external focus of attention is more effective than an internal focus for skill acquisition, more studies need to be conducted using various open perceptual-motor skills in different sport settings. The ability to perform under high pressure and in anxiety-provoking situations is a critical determinant of attainment in sports (Bortoli et al., 2012; Nicholls et al., 2005). Thus, it is proposed that the impact of external and internal training method in stress conditions, with novice children as participants, should be evaluated in the field. It is also suggested that future research be conducted to compare the effects of the two methods of focusing attention on different genders. Finally, another factor that requires further investigation is the complexity of perceptual-motor skills, and whether learning complex perceptual-motor skills is affected by the focus of attention in novice children.

AUTHOR CONTRIBUTIONS

Dr. Afroditi C. Lola: Study design, data collection, statistical analysis, and manuscript preparation; Andrianni Koutsomarkou (M.Sc.): Data collection; and Professor George Tzetzis: Study design, data collection, statistical analysis, and manuscript preparation.

SUPPORTING AGENCIES

No funding agencies were reported by the authors.

DISCLOSURE STATEMENT

No potential conflict of interest was reported by the authors.

REFERENCES

- Abdollahipour, R., & Psotta, R. (2017). Is an external focus of attention more beneficial than an internal focus to ball catching in children? *Kinesiology: International Journal of Fundamental and Applied Kinesiology*, 49(2), 235-241. <https://doi.org/10.26582/k.49.2.2>
- Abdollahipour, R., Nieto, M. P., Psotta, R., & Wulf, G. (2017). External focus of attention and autonomy support have additive benefits for motor performance in children. *Psychology of Sport and Exercise*, 32, 17-24. <https://doi.org/10.1016/j.psychsport.2017.05.004>
- Agar, C., Humphries, C. A., Naquin, M., Hebert, E., & Wood, R. (2016). Does varying attentional focus affect skill acquisition in children? A comparison of internal and external focus instructions and feedback. *Physical Educator*, 73(4), 639. <https://doi.org/10.18666/TPE-2016-V73-I4-6883>
- Al-Abood, S. A., Bennett, S. J., Hernandez, F. M., Ashford, D., & Davids, K. (2002). Effect of verbal instructions and image size on visual search strategies in basketball free throw shooting. *Journal of Sports Sciences*, 20(3), 271-278. <https://doi.org/10.1080/026404102317284817>
- American Association for Health, Physical Education, and Recreation. 1965. AAHPER Youth Fitness Test Manual, Washington, D.C.: the Association.
- Beilock, S. L., & Carr, T. H. (2001). On the fragility of skilled performance: What governs choking under pressure? *Journal of Experimental Psychology: General*, 130(4), 701. <https://doi.org/10.1037/0096-3445.130.4.701>
- Bell, J. J., & Hardy, J. (2009). Effects of attentional focus on skilled performance in golf. *Journal of Applied Sport Psychology*, 21(2), 163-177. <https://doi.org/10.1080/10413200902795323>
- Bortoli, L., Bertollo, M., Hanin, Y., & Robazza, C. (2012). Striving for excellence: A multi-action plan intervention model for shooters. *Psychology of Sport and Exercise*, 13(5), 693-701. <https://doi.org/10.1016/j.psychsport.2012.04.006>
- Brocken, J. E. A., Kal, E. C., & Van der Kamp, J. (2016). Focus of attention in children's motor learning: Examining the role of age and working memory. *Journal of Motor Behavior*, 48(6), 527-534. <https://doi.org/10.1080/00222895.2016.1152224>
- Chiviawosky, S. (2014). Self-controlled practice: Autonomy protects perceptions of competence and enhances motor learning. *Psychology of Sport and Exercise*, 15(5), 505-510. <https://doi.org/10.1016/j.psychsport.2014.05.003>
- Chiviawosky, S., Wulf, G., & Ávila, L. T. G. (2013). An external focus of attention enhances motor learning in children with intellectual disabilities. *Journal of Intellectual Disability Research*, 57(7), 627-634. <https://doi.org/10.1111/j.1365-2788.2012.01569.x>

- Chua, L. K., Dimapilis, M. K., Iwatsuki, T., Abdollahipour, R., Lewthwaite, R., & Wulf, G. (2019). Practice variability promotes an external focus of attention and enhances motor skill learning. *Human Movement Science, 64*, 307-319. <https://doi.org/10.1016/j.humov.2019.02.015>
- Denny, V. G. (2010). Where to focus attention when performing the jump float serve in volleyball. *Journal of Coaching Education, 3*(1), 56-68. <https://doi.org/10.1123/jce.3.1.56>
- Ducharme, S. W., & Wu, W. F. (2015). An external focus of attention improves stability after a perturbation during a dynamic balance task. *Journal of Motor Learning and Development, 3*(2), 74-90. <https://doi.org/10.1123/jmld.2015-0011>
- Emanuel, M., Jarus, T., & Bart, O. (2008). Effect of focus of attention and age on motor acquisition, retention, and transfer: a randomized trial. *Physical Therapy, 88*(2), 251-260. <https://doi.org/10.2522/ptj.20060174>
- Englert, C., Bertrams, A., Furley, P., & Oudejans, R. R. (2015). Is ego depletion associated with increased distractibility? Results from a basketball free throw task. *Psychology of Sport and Exercise, 18*, 26-31. <https://doi.org/10.1016/j.psychsport.2014.12.001>
- Fitts, P. M., & Posner, M. I. (1967). *Human Performance*. Belmont, CA: Brooks/Cole.
- Flores, F. S., Schild, J. G., & Chiviawosky, S. (2015). Benefits of external focus instructions on the learning of a balance task in children of different ages. *International Journal of Sport Psychology, 46*(4), 311-320.
- Ghorbani, S. (2019). Motivational effects of enhancing expectancies and autonomy for motor learning: An examination of the OPTIMAL theory. *The Journal of General Psychology, 146*(1), 79-92. <https://doi.org/10.1080/00221309.2018.1535486>
- Ghorbani, S., Dana, A., & Fallah, Z. (2019). The effects of external and internal focus of attention on motor learning and promoting learner's focus. *Biomedical Human Kinetics, 11*(1), 175-180. <https://doi.org/10.2478/bhk-2019-0024>
- Granados, C. (2010). The Effects of observation, dialogue, and attentional focus in dyadic training protocol. Unpublished Master's thesis, University of Nevada, Las Vegas.
- Hadler, R., Chiviawosky, S., Wulf, G., & Schild, J. F. G. (2014). Children's learning of tennis skills is facilitated by external focus instructions. *Motriz: Revista de Educação Física, 20*(4), 418-422. <https://doi.org/10.1590/S1980-65742014000400008>
- Haibach, P. S., Collier, D. H., & Reid, G. (2011). *Motor learning and development*. Champaign, IL: Human Kinetics.
- Hill, M. W., Duncan, M. J., Oxford, S. W., Kay, A. D., & Price, M. J. (2018). Effects of external loads on postural sway during quiet stance in adults aged 20-80 years. *Applied Ergonomics, 66*, 64-69. <https://doi.org/10.1016/j.apergo.2017.08.007>
- Kal, E. C., van der Kamp, J., & Houdijk, H. (2013). External attentional focus enhances movement automatization: A comprehensive test of the constrained action hypothesis. *Human Movement Science, 32*(4), 527-539. <https://doi.org/10.1016/j.humov.2013.04.001>
- Lawrence, G. P., Gottwald, V. M., Hardy, J., & Khan, M. A. (2011). Internal and external focus of attention in a novice form sport. *Research Quarterly for Exercise and Sport, 82*, 431-441. <https://doi.org/10.1080/02701367.2011.10599775>
- Lohse, K. R., Sherwood, D. E., & Healy, A. F. (2011). Neuromuscular effects of shifting the focus of attention in a simple force production task. *Journal of Motor Behavior, 43*(2), 173-184. <https://doi.org/10.1080/00222895.2011.555436>
- Lohse, K. R., Sherwood, D. E., & Healy, A. F. (2014). On the advantage of an external focus of attention: a benefit to learning or performance?. *Human Movement Science, 33*, 120-134. <https://doi.org/10.1016/j.humov.2013.07.022>

- Lohse, K. R., Wulf, G., & Lewthwaite, R. (2012). Attentional focus affects movement efficiency. Skill acquisition in sport: Research, theory & practice, 40-58.
- Lola, A. C., & Tzetzis, G. C., (2020). Analogy versus explicit and implicit learning of a volleyball skill for novices: The effect on motor performance and self-efficacy. *Journal of Physical Education and Sport*, 20(5), 2478-2486.
- Lola, A. C., Tzetzis, G. C., & Zetou, H. (2012). The effect of implicit and explicit practice in the development of decision making in volleyball serving. *Perceptual and Motor Skills*, 114(2), 665-678. <https://doi.org/10.2466/05.23.25.PMS.114.2.665-678>
- Maddox, M. D., Wulf, G., & Wright, D. L. (1999). The effect of an internal vs. external focus of attention on the learning of a tennis stroke. *Journal of Exercise Psychology*, 21(2), 78-85.
- Makaruk, H., Porter, J. M., Bodasińska, A., & Palmer, S. (2020). Optimizing the penalty kick under external focus of attention and autonomy support instructions. *European Journal of Sport Science*, 1-9. <https://doi.org/10.1080/17461391.2020.1720829>
- Makaruk, H., Porter, J. M., Czaplicki, A., Sadowski, J., & Sacewicz, T. (2012). Minerva Medica Copyright. *The Journal of Sports Medicine and Physical Fitness*, 52, 319-27.
- Marchant, D. C., Clough, P. J., & Crawshaw, M. (2007). The effects of attentional focusing strategies on novice dart throwing performance and their task experiences. *International Journal of Sport and Exercise Psychology*, 5(3), 291-303. <https://doi.org/10.1080/1612197X.2007.9671837>
- Marchant, D. C., Clough, P. J., Crawshaw, M. and Levy, A. (2009). Novice motor skill performance and task experience is influenced by attentional focusing instructions and instruction preferences. *International Journal of Sport and Exercise Psychology*, 7, 488-502. <https://doi.org/10.1080/1612197X.2009.9671921>
- Masters, R. S. (1992). Knowledge, knerves and know-how: The role of explicit versus implicit knowledge in the breakdown of a complex motor skill under pressure. *British Journal of Psychology*, 83(3), 343-358. <https://doi.org/10.1111/j.2044-8295.1992.tb02446.x>
- Nicholls, A. R., Holt, N. L., Polman, R. C., & James, D. W. G. (2005). Stress and coping among international adolescent golfers. *Journal of Applied Sport Psychology*, 17(4), 333-340. <https://doi.org/10.1080/10413200500313644>
- Niżnikowski, T., Sadowski, J., Niżnikowska, E., Miller, J. F., & Wiśniowski, W. (2017). Effectiveness of Different Types of Feedback in the Learning of Complex Movement Tasks. *Polish Journal of Applied Sciences*, 2(4), 129-132.
- Parr, R., & Button, C. (2009). End-point focus of attention: learning the 'catch' in rowing. *International Journal of Sport Psychology*, 40(4), 616-635.
- Perreault, M. E., & French, K. E. (2016). Differences in children's thinking and learning during attentional focus instruction. *Human Movement Science*, 45, 154-160. <https://doi.org/10.1016/j.humov.2015.11.013>
- Poolton, J. M., Maxwell, J. P., Masters, R. S. W., & Raab, M. (2006). Benefits of an external focus of attention: Common coding or conscious processing?. *Journal of Sports Sciences*, 24(1), 89-99. <https://doi.org/10.1080/02640410500130854>
- Porter, J. M., Anton, P. M., Wikoff, N. M., & Ostrowski, J. B. (2013). Instructing skilled athletes to focus their attention externally at greater distances enhances jumping performance. *The Journal of Strength & Conditioning Research*, 27(8), 2073-2078. <https://doi.org/10.1519/JSC.0b013e31827e1521>
- Porter, J. M., Ostrowski, E. J., Nolan, R. P., & Wu, W. F. (2010). Standing long-jump performance is enhanced when using an external focus of attention. *The Journal of Strength & Conditioning Research*, 24(7), 1746-1750. <https://doi.org/10.1519/JSC.0b013e3181df7fbf>

- Roshandel, S., Taheri, H., & Moghadam, A. (2017). Do children benefit from external focus of attention as much as adults? A motor learning study. *Modern Applied Science*, 11(7). <https://doi.org/10.5539/mas.v11n7p85>
- Saemi, E., Porter, J., Wulf, G., Ghotbi-Varzaneh, A., & Bakhtiari, S. (2013). Adopting an external focus of attention facilitates motor learning in children with attention deficit hyperactivity disorder. *Kinesiology: International Journal of Fundamental and Applied Kinesiology*, 45(2), 179-185.
- Shiffrin, R. M., & Schneider, W. (1977). Controlled and automatic human information processing: II. Perceptual learning, automatic attending and a general theory. *Psychological Review*, 84(2), 127. <https://doi.org/10.1037/0033-295X.84.2.127>
- Singh, H., & Wulf, G. (2020). The distance effect and level of expertise: Is the optimal external focus different for low-skilled and high-skilled performers? *Human Movement Science*, 73. <https://doi.org/10.1016/j.humov.2020.102663>
- Themanson, J. R., Pontifex, M. B., Hillman, C. H., & McAuley, E. (2011). The relation of self-efficacy and error-related self-regulation. *International Journal of Psychophysiology*, 80(1), 1-10. <https://doi.org/10.1016/j.ijpsycho.2011.01.005>
- Tsetseli, M., Zetou, E., Vernadakis, N., & Michalopoulou, M. (2016). The effect of internal and external focus of attention on game performance in tennis. *Acta Gymnica*, 46(4), 162-173. <https://doi.org/10.5507/ag.2016.021>
- Tsetseli, M., Zetou, E., Vernadakis, N., & Mountaki, F. (2018). The attentional focus impact on tennis skills' technique in 10 and under years old players: Implications for real game situations. *Journal of Human Sport and Exercise*, 13(2): 328-339. <https://doi.org/10.14198/jhse.2018.132.15>
- Tzetzis, G., & Lola, A. C. (2015). The effect of analogy, implicit, and explicit learning on anticipation in volleyball serving. *International Journal of Sport Psychology*, 46(2), 152-166.
- van Abswoude, F., Nuijen, N. B., van der Kamp, J., & Steenbergen, B. (2018). Individual differences influencing immediate effects of internal and external focus instructions on children's motor performance. *Research Quarterly for Exercise and Sport*, 89(2), 190-199. <https://doi.org/10.1080/02701367.2018.1442915>
- van der Graaff, E., Hoozemans, M., Pasteuning, M., Veeger, D., & Beek, P. J. (2018). Focus of attention instructions during baseball pitching training. *International Journal of Sports Science & Coaching*, 13(3), 391-397. <https://doi.org/10.1177/1747954117711095>
- Wulf, G. (2008). Attentional focus effects in balance acrobats. *Research Quarterly for Exercise and Sport*, 79(3), 319-325. <https://doi.org/10.1080/02701367.2008.10599495>
- Wulf, G. (2013). Attentional focus and motor learning: a review of 15 years. *International Review of Sport and Exercise Psychology*, 6(1), 77-104. <https://doi.org/10.1080/1750984X.2012.723728>
- Wulf, G., & Lewthwaite, R. (2010). Effortless motor learning? An external focus of attention enhances movement effectiveness and efficiency. *Effortless attention: A new perspective in attention and action*, 75-101. <https://doi.org/10.7551/mitpress/9780262013840.003.0004>
- Wulf, G., & Lewthwaite, R. (2016). Optimizing performance through intrinsic motivation and attention for learning: The OPTIMAL theory of motor learning. *Psychonomic Bulletin & Review*, 23(5), 1382-1414. <https://doi.org/10.3758/s13423-015-0999-9>
- Wulf, G., & Su, J. (2007). An external focus of attention enhances golf shot accuracy in beginners and experts. *Research Quarterly for Exercise and Sport*, 78(4), 384-389. <https://doi.org/10.1080/02701367.2007.10599436>
- Wulf, G., Chiviawsky, S., Schiller, E., & Ávila, L. T. G. (2010). Frequent external focus feedback enhances motor learning. *Frontiers in Psychology*, 1, 190. <https://doi.org/10.3389/fpsyg.2010.00190>

- Wulf, G., Höß, M., & Prinz, W. (1998). Instructions for motor learning: Differential effects of internal versus external focus of attention. *Journal of Motor Behavior*, 30(2), 169-179. <https://doi.org/10.1080/00222899809601334>
- Wulf, G., McConnel, N., Gärtner, M., & Schwarz, A. (2002). Enhancing the learning of sport skills through external-focus feedback. *Journal of Motor Behavior*, 34(2), 171-182. <https://doi.org/10.1080/00222890209601939>
- Wulf, G., McNevin, N., & Shea, C. H. (2001). The automaticity of complex motor skill learning as a function of attentional focus. *The Quarterly Journal of Experimental Psychology Section A*, 54(4), 1143-1154. <https://doi.org/10.1080/713756012>
- Wulf, G., Shea, C., & Park, J. H. (2001). Attention and motor performance: preferences for and advantages of an external focus. *Research Quarterly for Exercise and Sport*, 72(4), 335-344. <https://doi.org/10.1080/02701367.2001.10608970>
- Wulf, G., Wächter, S., & Wortmann, S. (2003). Attentional focus in motor skill learning: Do females benefit from an external focus?. *Women in Sport and Physical Activity Journal*, 12(1), 37-52. <https://doi.org/10.1123/wspaj.12.1.37>
- Yamada, M., Raisbeck, L. D., & Porter, J. M. (2020). The effects of using imagery to elicit an external focus of attention. *Research Quarterly for Exercise and Sport*, 1-7. <https://doi.org/10.1080/02701367.2020.1733455>
- Zetou, E., & Charitonidis, K. (2002). *The teaching of volleyball*. Thessaloniki: University Studio Press.

