



Universitat d'Alacant
Universidad de Alicante

Departamento de Física, Ingeniería de Sistemas y Teoría de la Señal

FUNDAMENTALS OF ENGINEERING PHYSICS I

Degree in Sound and Image Engineering in Telecommunications

Polytechnic University College

PROBLEMS PROPOSED

Augusto Beléndez Vázquez



Unit 1. Physical principles of semiconductors

1.- The model of free electrons for the behaviour of metals considers that electrons are completely free particles inside the conductor. In this model, and due to the Pauli exclusion principle, the probability that a given state with energy E is occupied by an electron is equal to $f(E)$, which is the fraction of states with that energy and which is known as the **Fermi factor** (Fermi-Dirac distribution):

$$f(E) = \frac{1}{e^{(E-E_F)/kT} + 1}$$

where E is energy, E_F is the Fermi energy or **Fermi level**, $k = 1.38 \times 10^{-23}$ J/K is the Boltzmann's constant and T is the absolute temperature. Calculate the value of the energies E for which the Fermi factor (the probability that a given state is occupied) is: (a) 1% and (b) 99%.

2.- In the free electron model, Fermi energy at absolute zero temperature is given by:

$$E_F = \frac{h^2}{8m_e} \left(\frac{3n}{\pi} \right)^{2/3}$$

where $h = 6.63 \times 10^{-34}$ J·s is Planck constant, $m_e = 9.11 \times 10^{-31}$ kg is the electron mass and n is the free electron concentration. Fermi energy shows the dividing line (in energy) between the states with the highest occupancy ($E < E_F$) and emptiness probability ($E > E_F$). Calculate the value of Fermi energy for copper at absolute zero temperature assuming that there is a free electron per each atom, that the copper density is 8.95×10^3 kg/m³ and that its atomic mass is 63.5 g/mol.

3.- The concentration of free electrons in copper at low temperatures is $n = 8.45 \times 10^{28}$ m⁻³. Using free-electron model, determine the Fermi energy for the solid copper and the value of the velocity of an electron whose kinetic energy equals the Fermi energy. Planck's constant, $h = 6.63 \times 10^{-34}$ J·s, electron mass, $m = 9.11 \times 10^{-31}$ kg.

4.- At absolute zero temperature, a semiconductor has a band structure, i.e., a forbidden E_G wide band gap separates the completely full valence band from the completely empty conduction band. However, at ordinary temperatures several electrons are excited and pass into the conduction band. Assuming that the Fermi energy of this semiconductor is half the band gap, calculate the value of the probability of occupying a specific state at the bottom of the conduction band for a temperature of 300 K if the width of the band gap is (a) 0.2 eV, (b) 1 eV, (c) 5 eV. Repeat the exercise for a temperature of 320 K.

5.- Determine, for an *n-type* semiconductor, the concentrations of electrons and holes depending on the donor impurity concentration N_D . Get the value of N_D so that the difference between the concentrations of electrons and donor impurities is less than 0.1% of N_D .



6.- It is known that for germanium, at a temperature of 300 K, intrinsic concentration is $n_i = 2.5 \times 10^{13} \text{ cm}^{-3}$. Determine, at that temperature, the concentrations of free electrons and holes, n and p , respectively, for a sample doped with germanium concentrations of acceptor and donor impurities $N_A = 10^{13} \text{ cm}^{-3}$ and $N_D = 2 \times 10^{13} \text{ cm}^{-3}$, respectively.

7.- For a semiconductor, the intrinsic concentration n_i is a function of temperature. It is known that the experimental relationship that quantifies this dependence is:

$$n_i^2(T) = A_0 T^2 e^{-E_{G0}/kT}$$

where A_0 is a constant, T is the absolute temperature, $k = 1.38 \times 10^{-23} \text{ J/K}$ is the Boltzmann constant and E_{G0} is the forbidden band gap at absolute zero temperature.

8.- A sample of *n-type* silicon in thermal equilibrium at a temperature of 300 K has a resistivity $\rho = 500 \text{ } \Omega \text{ m}$, electron and hole mobilities are $\mu_e = 0.16 \text{ m}^2 \text{ V}^{-1} \text{ s}^{-1}$ and $\mu_p = 0.06 \text{ m}^2 \text{ V}^{-1} \text{ s}^{-1}$, respectively, the intrinsic carrier concentration is $n_i = 1.4 \times 10^{16} \text{ m}^{-3}$ and the effective density of states in the conduction band (CB) is 10^{25} m^{-3} . If for the donor level $E_C - E_D = 0.05 \text{ eV}$, where E is the minimum energy of the conduction band and E_D is the energy of donor level, determine: (a) The concentrations of electrons and holes. (b) The energy of the Fermi level with respect to the energy of the CB. (c) The probability for a state of the donor level to be occupied and the probability to be not occupied.

9.- A *pn* junction diode has a saturation current of 0.5 mA at a temperature of 300 K. If we know that the value of the Boltzmann constant $k = 1.38 \times 10^{-23} \text{ J / K}$, determine the current at that temperature when the voltage has a value of 1, -1, 100 and -100 mV.

10.- A *pn* junction diode has a saturation current of 1 nA and $kT = 0.025 \text{ eV}$ at room temperature. (a) Find the value of the resistance for small reverse bias voltages. (b) Calculate the values of current and resistance of the diode in reverse bias when applying a voltage of 0.5 V. (c) Calculate the values of current and resistance of the diode in forward bias when applying a voltage of 0.5 V.

Unit 2. Kynematics

1.-The elastic constant of a spring has been determined experimentally using two different procedures, and the values obtained were 8 g/cm are 7840 g/s², are consistent both results?

2.- Express the following quantities in units of the International System, clearly indicating the process of obtaining the final result: (a) a tire pressure of 1.7 kg/cm². (b) An energy consumption of 200 kWh. (c) The gravitational constant is $G = 6.7 \times 10^{-8} \text{ cm}^3 \text{ g}^{-1} \text{ s}^2$.

3.- In the equation $v = k\sqrt{D(d-1)}$, $k = 3.62$ when D is expressed in m and v en m/s, where d is the relative specific weight. What is the value of k for expressing D in mm and v is in cm/s?

4.- An equation that relates the velocity v with the distance x is $v^2 = C_1/x$, where C_1 is a constant. (a) What are the dimensions of the constant C_1 ? (b) If the units of the velocity v are m/s and the displacement x is expressed in m, what are the units of C_1 ?

5.- In equations (1) $x = C_1 + C_2t + C_3t^2$ and (2) $x = C_1 \sin C_2t$, the distance x is expressed in meters and the time t in seconds. (a) What are the units of C_1 , C_2 and C_3 in the International System? (b) What are their dimensions?

6.- If we don't remember which of the following three formulas is the correct for the period T of a simple pendulum, $T = 2\pi\sqrt{g/l}$, $T = 2\pi\sqrt{l/g}$ or $T = 2\pi\sqrt{m/g}$, where l is the length of the massless cord, m is the mass of the pendulum bob and g is acceleration due to gravity, how can we know quickly which one is the correct?

7.- Show that force, velocity and acceleration can form a system of fundamental magnitudes for Mechanics. What dimensions will have the volume, the angular velocity and the density in this system of units?

8.- Given two vectors $\mathbf{A} = 5\mathbf{i} + 3\mathbf{j} + 4\mathbf{k}$ and $\mathbf{B} = 6\mathbf{i} - \mathbf{j} + 2\mathbf{k}$, (a) find the magnitude of each vector, (b) find the scalar product $\mathbf{A} \cdot \mathbf{B}$, (c) find the angle between these two vectors, (d) find the director cosines of each vector, (e) find $\mathbf{A} + \mathbf{B}$ and $\mathbf{A} - \mathbf{B}$, (f) find the vector product $\mathbf{A} \times \mathbf{B}$.

9.- The edges of a parallelepiped are given by the vectors $\mathbf{A} = \mathbf{i} + 3\mathbf{j}$, $\mathbf{B} = 7\mathbf{j}$ and $\mathbf{C} = \mathbf{j} + 2\mathbf{k}$. Find the parallelepiped volume if the magnitude of each unit vector \mathbf{i} , \mathbf{j} and \mathbf{k} is 1 cm.

10.- Given the vector $\mathbf{a} = \mathbf{i} - 2\mathbf{j} - 3\mathbf{k}$ and the point $A(2,1,0)$ belonging its line of action, find the momentum of this vector about the origin of the coordinate system.

11.- An object travels in the x -direction so that its velocity as a function of time is given by the equation $v(t) = t^3 + 4t^2 + 2$ m/s, where v is the velocity and t is the time.



We know that for $t_0 = 2$ s the object is in the position $x_0 = 4$ m. Find the position and the acceleration of the object at $t = 3$ s.

12.- The acceleration of an object that travels in the x -direction is given by $a(x) = 4x - 2$ m/s². If its velocity is $v_0 = 10$ m/s at $x_0 = 0$ m, find its velocity for any position x .

13.- A particle describes a movement in the xy -plane so that the Cartesian components of its velocity vector expressed in the International System, are $v_x(t) = 4t^3 + 4t$ and $v_y(t) = 4t$. If the particle is at the point of coordinates (1.2) at $t_0 = 0$ s, find the Cartesian equation of its trajectory.

14.- A particle describes a trajectory in the xy -plane so that the parametric equations describing its motion are $x(t) = pt$, $y(t) = \frac{1}{2}pt^2$, where p is a constant. Find: (a) The Cartesian components of the velocity and acceleration vectors as a function of time, and their magnitudes. (b) The intrinsic components of the acceleration. (c) The radius of curvature of the trajectory.

15.- An object is thrown vertically upward with a speed of 98 m/s, from the edge of the roof of a 100-m-tall building. The object doesn't hit the building on its back down and lands in the street below. Find: (a) The maximum height reached by the object as measured from the street. (b) The time when the object passes through its launch site. (c) The speed of the object just before it hits the street. (d) The time elapses from when the object is thrown until it hits the street.

16.- From the top of a tower, a rock is thrown vertically upward with an initial speed of 15 m/s. If the origin of coordinates is taken at the launch point of the rock, find: (a) The position and the velocity of the rock after 1 s and 4 s since its launch. (b) The speed of the rock when it is 8 m above the launch point. (c) The time elapsed since the launch of the rock until it returns to pass again through the launch point. (c) The time elapsed since the launch of the rock until it returns to pass again through the launch point.

17.- A wheel of diameter 20 cm is rotating at 3000 rev/min. A brake is applied to the wheel and we notice that it stops after 20 s. Find: (a) The angular acceleration (assume it to be constant) and the number of revolutions done by the wheel until it stops. (b) The tangential and normal accelerations of a point on the rim of the wheel once it has done one hundred revolutions, and the resultant acceleration at that point.

18.- A beacon rotates with a constant angular velocity ω . If the lighthouse is placed at a distance d from a beach completely straight, find: (a) The velocity and the linear acceleration that the light spot moves on the beach when the angle between d and the light beam is θ .

19.- A projectile is being launched from ground level with no air resistance at an angle of 40° above the horizontal with a velocity of 200 m/s. (a) Find the velocity and

the position of the projectile 20 s after its launch. (b) How far beyond the launch point will the projectile hit the ground? Find the time when the projectile hits the ground.

20.- A stone with a initial speed v_0 at an angle 90° above the surface of an incline, which is itself inclined at an angle α above the horizontal, a stone is thrown with a initial speed v_0 perpendicular to the incline. Find the distance, measured along the incline, from the launch point to the point when the stone strikes the incline.

21.- A boy of 1.5 m in height is placed 15 m away from a wall of 5 m in height and throws a stone at the wall with a speed that makes an angle of 45° to the horizontal. What is the minimum value of the speed with which the boy must release the stone so that it passes over the wall?

22.- A lift of 3 m in height begins to rise at a constant acceleration of 1 m/s^2 . When the elevator is at a certain height, it follows the chandelier. What is the time it takes for chandelier to strike the floor of the lift?

Unit 3. Dynamics

1.- A 5-kg block hangs from one end of a massless, inextensible rope. The block is pulled vertically upward with an acceleration of 2 m/s^2 . (a) Find the tension in the rope while the block is moving. (b) When the block is moving, the tension in the rope is reduced to 49 N, what kind of motion will do the block? (c) If the rope is loosened completely we observe that the block goes up 2 m before stopping, what was the speed of the block?

2.- Two blocks of masses $m_1 = 20 \text{ kg}$ and $m_2 = 15 \text{ kg}$ are in contact on a horizontal, frictionless surface, as shown in figure. A horizontal force $F = 40 \text{ N}$ is exerted on block m_1 . Find: (a) The acceleration of the system. (b) The magnitude of the force between the two blocks. Repeat the problem if the coefficient of friction between the blocks and the surface is $\mu = 0.02$.

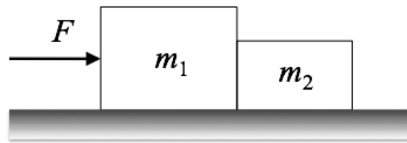

3.- A block slides down a 30° incline. After reaching the bottom, it moves on a horizontal plane and then the blocks stops. Find the coefficient of friction between the block and the surfaces if the distance run by the block, before stopping, on the inclined plane is the same as in the horizontal plane.

4.- A 105 kg sled slides on a horizontal track covered in snow at 36 km/h. The coefficient of friction between the sled and the snow is $\mu = 0.025$. (a) Find the time elapsed before the sled stops. (b) How far does the sled travel in this time.

5.- Two blocks of 16 kg and 8 kg are on a frictionless horizontal surface. The blocks are connected by a rope A and are they are pulled to the right at a constant acceleration of 0.5 m/s^2 by a second rope B. Find the tension in the rope A connecting the blocks.

6.- Two blocks A and B with masses 200 kg and 100 kg, respectively, are connected as it can be seen in the figure. Block B is on an inclined plane of angle 30° and a frictionless, light string attached to block B passes over a frictionless, massless pulley. Block A is suspended from the pulley. The coefficient of friction between the block B and the inclined plane is $\mu = 0.25$. Find the acceleration of each one of the blocks if they move from the rest.

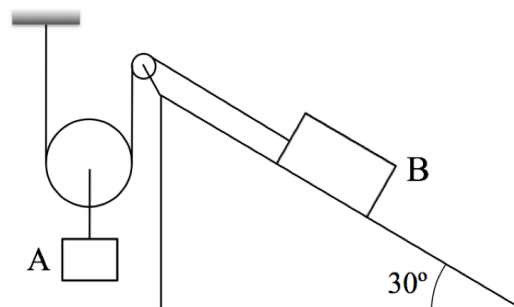

7.- Three identical blocks of 2 kg are connected by two massless strings, over a light, frictionless pulley. Find the acceleration of the system and the tension in string between blocks A and B.

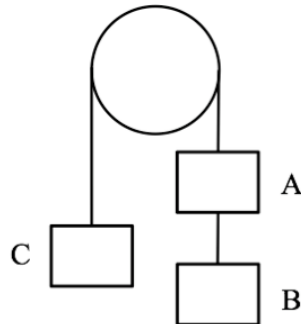

8.- Find the difference in level between the outer and inner edges of a banked curve with a 600-m radius having a width of 7.2 m, so an automobile can safely round the curve at 80 km/h without experiencing lateral forces.

9.- A particle of mass m is suspended from a massless, inextensible rope of length is L . The other end of the rope is fixed to a vertical axis that rotates with constant angular velocity ω dragging the rope and the mass m in its rotation. Find, as a function of ω , the angle θ between the rope and the vertical.

10.- A particle of mass 2 kg does a curve in the space whose parametric equations are $x(t) = t^3$, $y(t) = t - 2t^2$ and $z(t) = \frac{1}{4}t^4$, where t is the time. Find, for $t = 2$ s: (a) The velocity and acceleration vectors and their magnitudes. (b) The linear momentum vector. (c) The angular momentum of the particle about the origin of coordinates. (d) The force acting on the particle.

11.- The movement of a particle of 2 kg in the xy -plane is specified by the position vector $\mathbf{r}(t) = 3t\mathbf{i} + 4t^2\mathbf{j}$. Find: (a) The moment of the force acting on the particle about the origin of coordinates. (b) The linear momentum of the particle. (c) The angular momentum of the particle about the origin of coordinates.

12.- A bullet goes through the mouth of a rifle at 500 m/s. We know that the resultant force exerted by the gases on the bullet is given by the equation $F(t) = 800 - 2 \times 10^5 t$ (in units of the International System) where t is the time. (a) Plot of force F versus time t . (b) Determine the time the bullet was into the rifle if value of force F in the mouth of the rifle is 200 N. (c) Determine the impulse exerted on the bullet and the mass of the bullet.

Unit 4. Work and energy

1.- We push a 1000 kg block 6 m along a horizontal surface with constant velocity. The angle between the force F and the horizontal is 30° and the coefficient of friction between the block and the horizontal surface is $\mu = 0.3$. What is the work done by the force F ?

2.- A 3 kg object is dropped from a height at an initial velocity of $v_0 = 2$ m/s, directed vertically downward. Find the work done during a time interval of $t = 10$ s, against the air resistance force, if at the end of this interval the object's velocity is $v = 50$ m / s. Consider that the air resistance force is constant.

3.- A 5 kg block is thrown upward along a ramp that is inclined 30° below the horizontal. The initial velocity is $v_0 = 5$ m/s and it is parallel to the ramp. Find the height reached by the block: (a) If there is no friction between the block and the ramp. (b) If the coefficient of friction between the block and the ramp is $\mu = 0.1$.

4.- A 5 kg block is thrown upward along a ramp that is inclined 30° below the horizontal. The initial velocity is $v_0 = 5$ m/s and it is parallel to the ramp. If the block rises 1.5 m for the inclined plane, stops and returns to the starting point, find the frictional force between the block and the incline and the speed of the block when it returns to the starting point.

5.- A 10 kg block sliding down along a ramp that is inclined 60° below the horizontal, driven by a force F forming an angle of 30° with the inclined plane, as shown in the figure. The coefficient of friction between the block and the incline is $\mu = 0.2$. (a) Find the acceleration with which the block down the inclined plane. (b) If the block is at rest at the highest point A, find its speed when it reaches the lowest point B as well as the time spent on travel the distance AB. (c) Find the work done by the force F and the energy lost by friction.

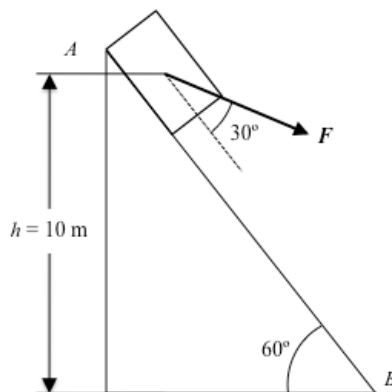

6.- A 200 g stone is tied to the end of an inextensible, massless string of length $L = 1$ m and is rotated in a vertical plane. (a) Find the minimum speed, which is needed for this. (b) If the speed is doubled, determine the tension of the string at the highest point and the lowest. (c) If the string breaks at the time the stone passes through the highest point, how do the stone move?

7.- A 1 kg block starts from rest and slides down along a ramp that is inclined 30° below the horizontal. If the coefficient of friction between the block and the inclined plane is $\mu = 0.2$, find: (a) The acceleration of the block. (b) The time the block takes to travel 10 m along the plane. (c) The speed of the block after going through these 10 m along the inclined plane.

8.- A small object with a mass $m = 0.25$ kg is at rest on a small platform attached to a spring in position A, when the spring is compressed 6 cm. Then, the platform is released, so that the object moves without friction around the arc ABCDE of the figure. Find the minimum value of the spring elastic constant k so that the object moves around the arc without falling off at the top (point C).

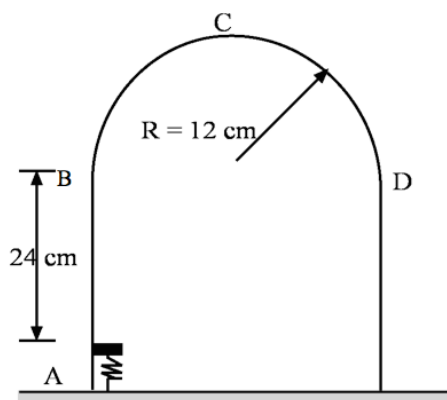

9.- A small object rolls without friction around the track shown in the figure. It starts from the rest at a point at a height h above the bottom of the loop. What is the minimum value of h (in terms of R) such as the object moves around the loop without falling off at the top of the vertical circumference of radius R .

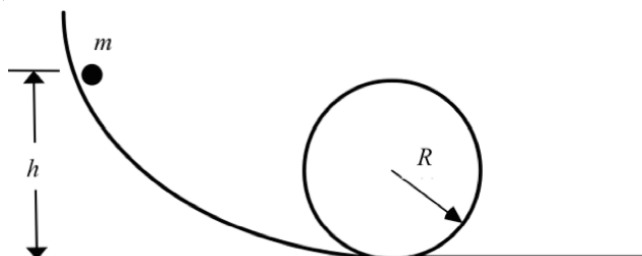

10.- Blocks A and B move on a frictionless, horizontal surface. Initially, block B is at rest and block A is moving (to the right) toward the box B at 0.5 m/s. The collision is head-on (so all motion before and after collisions is along a straight line) and after it the block A rebounds at 0.1 m/s, while the blocks B moves to the right at 0.3 m/s. In a second experiment, the block A is overcharged with an additional mass of 1 kg and is thrown into the box B at 0.5 m/s. After this second collision, the block A is at rest while the box B moves to the right at 0.5 m/s. Find the values of the masses of the two blocks.

Unit 5. Heat and temperature

1.- (a) A carpenter uses a steel measuring tape whose length is 50 m at a temperature of 20°C. (a) Find the length of the tape at a temperature of 40°C. (b) The same carpenter uses the tape to measure the width of a wood plank when the temperature is 40°C and the value that he reads off the tape is 3.5794 m. Determine the actual width of the plank if the tape is calibrated for use at 20°C. The coefficient of linear expansion of steel is $\alpha = 1.2 \times 10^{-5} \text{ K}^{-1}$.

2.- A 250-cm³ glass flask is filled to the brim with mercury at a temperature of 25°C. Find amount of mercury that overflows when the temperature of the system is raised to 100°C. The coefficient of linear expansion of the glass is $0.4 \times 10^{-5} \text{ K}^{-1}$ and the coefficient of volume expansion of the mercury is $18 \times 10^{-5} \text{ K}^{-1}$.

3.- The standard temperature and pressure (STP) is an state of an ideal gas defined as a temperature of 0°C = 273.15 K and a pressure of 1 atm = $1.013 \times 10^5 \text{ Pa}$. What volume should have a container that holds one mole of an ideal gas in a room at STP?

4.- A mixture of air and vaporized gasoline is compressed in the cylinders of an automobile engine before being ignited. We know that a typical engine has a compression ratio of 9 to 1, which means that the gas in the engine cylinder is compressed to a final volume, which is 1/9 of its original volume. If the initial pressure and temperature are 1 atm and 27°C, respectively, and the pressure after compression is 21.7 atm, find the temperature of compressed gas.

5.- The volume of a tank used for scuba diving is 11 L and the gauge pressure when filled, is $2.10 \times 10^7 \text{ Pa}$. When the tank is “empty”, it contains 11 L of air at a temperature of 21°C and a pressure of 1 atm ($1,013 \times 10^5 \text{ Pa}$), whereas when the tank is filled with hot air from a compressor, the temperature rises to 42°C and the gauge pressure is still $2.10 \times 10^7 \text{ Pa}$. Determine the mass of air that is added to the tank, knowing that the air is a mixture of gases: approximately 78% nitrogen, 21% oxygen and 1% other gases, and their average molecular mass is 28.8 g / mol.

6.- In the atmosphere, pressure p varies with height y according to the general equation $dp/dy = -\rho g$, where ρ is the density and g the acceleration due to gravity. Find the atmospheric pressure variation with height, assuming that the temperature is 0°C at all points and ignoring the variation of the acceleration of gravity g with height.

7.- We are designing an electronic circuit element made of 23 mg of silicon whose electrical resistance is $R = 1850 \Omega$, so that electrical current passing through it is $I = 2 \text{ mA}$. If the design does not include the removal of heat from the element, how quickly will its temperature increase? The specific heat of silicon is $705 \text{ J kg}^{-1} \text{ K}^{-1}$.

8.- A Physics student wants to cool 330 g of a low-calorie drink (almost pure water), which is at a temperature of 25°C, adding ice cubes at -20°C. Determine the mass of ice that the student must add to the drink to reduce the temperature until 0°C with all the ice melted. Assume the heat capacity of the glass can be neglected. Specific heats: water, $4190 \text{ J kg}^{-1} \text{ K}^{-1}$, ice, $2100 \text{ J kg}^{-1} \text{ K}^{-1}$. Ice latent heat of fusion, 334 J/kg.



9.- An engineer, who visits every day a building to check its telecommunications infrastructure, drinks his morning coffee in a 120 g cup of aluminium. Every morning, the cup is initially at a temperature of 20°C when he pours over 200 g of coffee that is initially at 75°C. Determine the final temperature reached by the coffee and the cup in the thermal equilibrium bearing in mind that the specific heat of aluminium is $910 \text{ J kg}^{-1} \text{ K}^{-1}$ and assuming that coffee has the same specific heat as water, $4190 \text{ J kg}^{-1} \text{ K}^{-1}$, and that no heat is exchanged with the surroundings.

10.- A cooking pot is made of copper and its mass, including the lid of the pot is 2 kg. The pot is initially at a temperature of 150°C and we pour 100 g of water at 25°C into it, quickly covering it in avoid any water vapour leak. Determine the final temperature of the pot and its contents and determine the phase (liquid or gas) of water. Assume that no heat is lost to the surroundings. The specific heat of water and copper are $4190 \text{ J kg}^{-1} \text{ K}^{-1}$ and $390 \text{ J kg}^{-1} \text{ K}^{-1}$, respectively.

11.- A room at 20°C has a 2 m wide and 2.5 m high glass window, with a thickness of 3 mm. Find the heat lost per minute by conduction through the window, knowing that the outside air temperature is 12°C and the thermal conductivity of glass is $0.0025 \text{ cal cm}^{-1} \text{ s}^{-1} \text{ K}^{-1}$.

12.- We use a polystyrene foam box to keep drinks cold. The box, with a total wall area (including the lid) of 0.8 m^2 and a wall thickness is 2 cm, is filled with ice, water and low-calorie soda cans (virtually water) at a temperature of 0°C. Determine the heat flow inside the box if outside temperature is 30°C, together with the amount of ice that melts in a day, knowing that the thermal conductivity of polystyrene foam is $0.01 \text{ W m}^{-1} \text{ K}^{-1}$ and the heat of fusion of ice is $3.34 \times 10^5 \text{ J/kg}$.

13.- We fabricate a fridge using wood ($k_w = 0.0006 \text{ cal cm}^{-1} \text{ s}^{-1} \text{ K}^{-1}$) with a thickness of 1.75 cm lined inside with cork ($k_c = 0.0012 \text{ cal cm}^{-1} \text{ s}^{-1} \text{ K}^{-1}$), with a thickness of 3 cm. If the temperature on the inner surface of the cork is 0°C and on the outer surface of the wood is 12°C, what is the temperature at the interface wood-cork?

14.- A steel bar has a length of 10 cm and is butt welded with a copper bar whose length is 20 cm, so the system length is 30 cm. The two bars are perfectly isolated by their sides and have the same transversal square section of 2 cm. The free end of the steel bar is kept at a temperature of 100°C by placing it in contact with water vapour, while the free end of the copper bar is kept at 0°C by placing it in contact with ice. Under these conditions, determine the temperature at the junction of the two bars and the total heat flux knowing that the thermal conductivities of steel and copper are $50.2 \text{ W m}^{-1} \text{ K}^{-1}$ y $385 \text{ W m}^{-1} \text{ K}^{-1}$, respectively.

15.- A wall of thickness h is built by placing one above the other, two rectangular plates of thickness h , sections S and S' , and conductivities k and k' respectively. If each side of the complete wall is at temperatures T_1 and T_2 , respectively, determine, in the steady state, the flow of heat through the wall per unit time, and the equivalent conductivity of the wall.

16.- Human body has a total surface area of approximately 1.2 m^2 being its surface temperature 30°C . Determine the total rate of radiation energy in the body. In the case that the environment is at 20°C , calculate the net rate of heat loss of the body due to radiation. The emissivity of the human body is very close to unity, irrespective of the skin pigmentation, and the value of the Stefan- Boltzmann constant is $\sigma = 5.67 \times 10^{-8} \text{ Wm}^{-2}\text{K}^{-4}$.

Unit 6. Thermodynamics

1.- For the following processes indicate the signs of heat and work: (a) An anvil is beaten with a hammer and then is cooled. (b) The CO₂ gas into a rigid container is heated and both temperature as pressure increase. (c) A mixture of H₂ and O₂ in a cylinder with adiabatic walls exploited by the action of a spark and the piston moves, so that the volume of the gas increases. (d) A metal spring is compressed sharply.

2.- In a certain process 500 cal of heat are added to a system and a mechanical work of 100 J is done on the same system. Find the change in internal energy of the system.

3.- A thermodynamic system changes from an initial state A to an state B and then backs again to A, via the state C, as shows the path A-B-C-A on the pV -diagram in the figure. (a) Complete the table in the figure placing the appropriate sign (+) or (-) to the thermodynamic quantities in each process. (b) Calculate the numerical value of work done by the system during the cycle A-B-C-A.

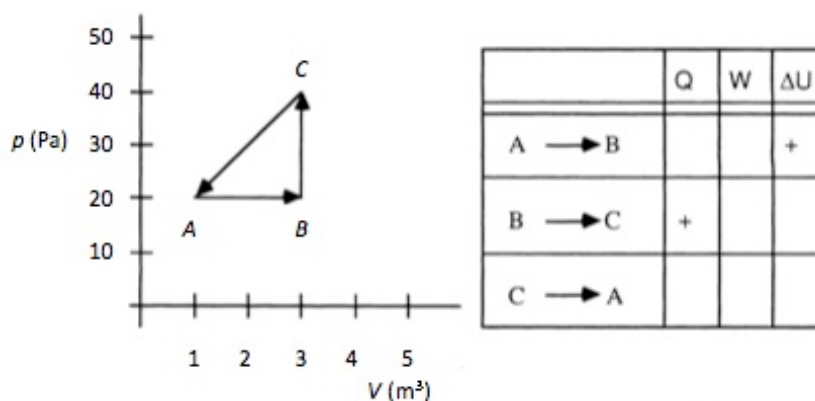

4.- The initial temperature and pressure of 1 mol of an ideal gas are 0°C and 1 atm. The gas is compressed reversibly and adiabatically until its temperature rises to 10°C. The gas is then expanded reversibly and isothermally until its pressure is 1 atm again. (a) Find the pressure after the adiabatic compression. (b) Calculate the total change in internal energy of the gas. (c) Calculate the heat and work for the complete process. Consider $C_p = 20.5 \text{ J K}^{-1} \text{ mol}^{-1}$ and $R = 8.3 \text{ J K}^{-1} \text{ mol}^{-1}$.

5.- One litre of oxygen (O₂) under normal pressure and temperature is expanded to a volume of 3 litres. (1) isothermally, (2) isobarically. Calculate, in each case: (a) The final pressure. (b) The final temperature. (c) The change in the internal energy. (d) The work done. (e) The heat supplied. ($C_p = 7 \text{ cal K}^{-1} \text{ mol}^{-1}$).

6.- Demonstrate the Reech's law: "the slope of the adiabatic curves is γ times greater than the slope of the isotherm curves".

7.- 20 g of nitrogen gas (N₂) originally at a temperature of 27°C are compressed reversibly and adiabatically from an initial volume of 17 litres to a final volume of 11 litres. Calculate the work done on the system and the change in its internal energy.

8.- 0.1 moles of a diatomic ideal gas at an initial temperature of 273 K are in the bottom of the container of the figure. The piston has an area of 50 cm^2 and a mass of 100 kg and it is at a height h . The gas is heated and the piston moves up 10 cm. Calculate the value of the height h , the final temperature, the variation in internal energy of the gas and the heat added.

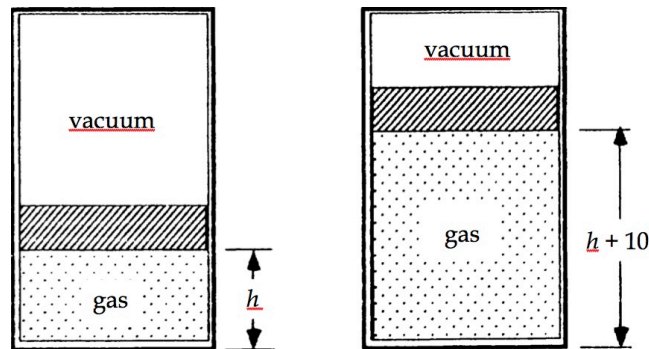

9.- 200 cm^3 of dry air in a cylinder expands from a pressure of 10 to 1 atm. If the initial temperature of dry air is 10°C , calculate the final volume and the final temperature if the expansion is: (a) isothermal, (b) adiabatic. Calculate the work done in each case. ($C_v = 5 \text{ cal K}^{-1}\text{mol}^{-1}$).

10.- A heat engine operates between the temperatures of 127°C and 27°C with a heat input of 1200 J from the hot reservoir. The thermal efficiency of this heat engine is 80% of that of a Carnot engine operating between the same temperatures. Calculate: (a) The work done per cycle. (b) The heat discarded to the cold reservoir per cycle. (c) The variation of entropy of the universe per cycle.

11.- A Carnot refrigerator is operated between two heat reservoirs at temperatures of 0°C and 100°C . In each cycle the refrigerator receives 1 J of heat energy from the cold reservoir. (a) How much mechanical energy is required each cycle to operate the refrigerator? (b) During each cycle, how many joules of heat energy are discarded to the high-temperature reservoir?

12.- A system absorbs 300 cal from a reservoir at 300 K and 200 cal from a reservoir at 400 K. The system returns to its original state doing a work of 100 cal and giving 400 cal to a third reservoir at a temperature T . (a) Calculate the entropy variation during each cycle and the thermal efficiency of this cycle. (b) If the cyclic process is reversible, what is the value of the temperature T ?

13.- An engine of a ship operating on a Carnot cycle extracted heat from sea water at a temperature of 18°C and discards heat to a reservoir of dry ice at -78°C . If the engine has to develop a power of 8000 hp, how much dry ice will be consumed during the course of a day? Latent heat of sublimation of dry ice, $L_s = 137 \text{ cal/g}$. 1 hp (horsepower) = 736 W.

14.- Calculate the change in entropy when the equilibrium is reached if we mix 100 g of ice at 0°C and 20 g of steam at 100°C in an insulated container. The latent heats of melting and vaporization of ice and water vapour are $L_f = 80 \text{ cal/g}$ and $L_v = 540 \text{ cal/g}$, respectively.

Unit 7. Electric field

1.- Two equal positive point charges $q_1 = 2 \times 10^{-6}$ C are placed at two adjacent corners of a square with a side length $a = 1$ m, while two other equal positive charges $q_2 = 5 \times 10^{-6}$ C are placed in the other corners. Calculate the electric field and the electric potential at the centre of the square.

2.- Point charges $q_1 = -10^{-8}$ C and $q_2 = 10^{-8}$ C are separated by 10 cm in air, forming an electric dipole. Find the electric field produced by the dipole at the following positions: (a) At a distance of 5 cm from the positive charge along the direction of the line joining the charges. (b) At a point in that line at a distance of 4 cm of positive charge. (c) At a point equidistant 10 cm from both charges.

3.- There is a uniform electric field between two very large parallel plates with equal but opposite charges. An electron is released at rest on the surface of the negative plate and then, after $t = 15$ ns, it reaches the surface of the other plate, placed at a distance $d = 2.0 \times 10^{-2}$ m. (a) Calculate the intensity of the electric field (b) and the velocity of the electron when it reaches the second plate. (c) Which is the potential difference between the plates?

4.- An electron is projected within a uniform electric field $E = 2000$ N/C with an initial velocity $v_0 = 10^6$ m/s perpendicular to the field. (a) Find the motion equations of the electron. (b) How much will the electron deflect if it has travelled 1 cm on the x -axis, assuming that this axis determines the input direction of the electron? $m = 9.1 \times 10^{-31}$ kg, $q = -1.6 \times 10^{-19}$ C

5.- A charge q is uniformly distributed along a conducting ring of radius a . Find the electric field and the electric potential at an arbitrary point on the axis perpendicular to the ring plane and passing through the centre of the ring, as a function of the distance from this centre.

6.- Calculate the electric field and the electric potential produced by: (a) a segment of length L uniformly charged with linear charge density λ (\mathbf{E} and V evaluated in points of the segment bisector); (b) an infinite line uniformly charged with linear charge density λ .

7.- A positive electric charge is distributed uniformly throughout the volume of an insulating sphere with radius R , being ρ the volume charge density. Find the magnitude of the electric field in points inside and outside the sphere as a function of the distance r from the its centre.

9.- An insulating sphere with radius R has a volume density charge proportional to the distance r from its centre $\rho = Ar$ for $r \leq R$, and $\rho = 0$ for points $r > R$, where A is a constant. Calculate: (a) The value of the constant A if the total charge of the sphere is Q . (b) The magnitude of the electric field in points inside and outside the sphere as a function of the distance r from its centre.

10.- The surface charge densities of three parallel infinite plane sheets placed at $x = -2$, $x = 0$ and $x = 2$ m, are $\sigma_1 = 2 \text{ C/m}^2$, $\sigma_2 = 4 \text{ C/m}^2$ and $\sigma_3 = -3 \text{ C/m}^2$, respectively. Calculate the electric field and the potential produced by the three charged sheets in the different regions of the space determined by them, considering the potential is null at $x = 0$ m.

Unit 8. Conductors, capacitors and dielectrics

1.- Two concentric conducting spherical shells with radius a and b ($a < b$) have electric potentials V_1 and V_2 , respectively. Calculate the electric charge on each of the shells.

2.- Let us consider two concentric isolated conducting spherical shells with radius a and b ($a < b$). The spherical shell of radius a is discharged and the spherical shell of radius b has a total charge Q on its surface. The inner spherical shell is connected to ground without touching the outer spherical shell. What is the charge induced in the spherical shell of radius a ? What is the potential in the points between the two spherical shells?

3.- Two concentric isolated conducting spherical shells with radius $R_1 = 5$ cm and $R_2 = 10$ cm, have electric potentials $V_1 = 30000$ V and $V_2 = 18000$ V, respectively. The inner spherical shell is connected to ground without touching the outer spherical shell, which will be the potential of the outer spherical shell?

4.- A conducting sphere with radius R_1 and charge Q is connected, using a conducting wire, whose capacitance is negligible, to another sphere of radius R_2 ($R_2 < R_1$), initially discharged. Assuming that the spheres are sufficiently far apart in order influence phenomena between them to be negligible, calculate: (a) The charges of each one of the spheres. (b) The potential. (c) The charge surface density of each sphere. (d) Repeat the exercise assuming that the distance between the centres of the two spheres is d .

5.- A copper slab with a thickness b , is inserted between the two flat plate of a parallel-plate capacitor. The copper slab is located exactly half the distance d ($d > 0$) between the plates. What is the capacitance before and after inserting the copper slab?

6.- The plates of a parallel-plate capacitor are separated $d = 5$ mm and have a surface $S = 2$ m². We introduce two dielectrics between them, one with a thickness of 2 mm and with a relative permittivity of 5, and another one with a thickness of 3 mm and a relative permittivity of 2. The capacitor is charged up to 3.54×10^{-5} C. Calculate: (a) The electric field in each dielectric. (b) The electric potential difference between the plates of the capacitor. (c) The capacitance of the capacitor.

7.- Given the system of the figure, calculate the energy stored by each capacitor if the potential difference between points A and B is $V = 20$ V, being $C = 4$ μ F.

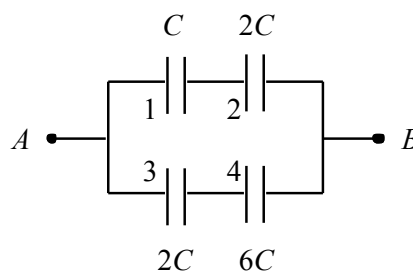

8.- Two capacitors connected in parallel accumulate an energy of 9×10^{-4} J when there is a potential difference of 5000 V between plates. When these capacitors are connected in series and we establish the same potential difference between the extreme plates, energy is 2×10^{-4} J. Find the capacitances of both capacitors.

9.- In a parallel plate capacitor with plate area S and a separation d between plates, a battery charges the plates with a potential difference V_0 , then it is disconnected and we insert a dielectric with a thickness d . Calculate the energy before and after inserting the dielectric.

10.- (a) Calculate the energy stored in a conducting sphere of radius R and total charge Q . (b) What would the stored energy be in the case of a non-conducting sphere of radius R and charge Q uniformly distributed throughout its volume?

Unit 9. Electric current

1.- A copper wire, with a circular cross section of 1 cm of diameter, carries a current of 100 A. Copper has 8.5×10^{22} free electrons per cm^3 and its resistivity at ambient temperature is $1.72 \times 10^{-8} \Omega\text{m}$. Calculate: (a) The current density in the wire in A/m^2 . (b) The drift velocity of the free electrons. (c) The value of the electric field inside the wire.

2.- Find the density of free electrons n for a copper wire if there is a free electron for each copper atom. If the maximum recommended current for a copper wire of 0.81 mm of radius (as the ones used domestically) is 15 A, what is the drift velocity of the electrons in the wire?

3.- A copper wire has a circular section of 1.02 mm of diameter and carries a current of 1.67 A. The resistivity is $1.72 \times 10^{-8} \Omega\text{m}$ at a temperature of 20°C . Calculate, at 20°C : (a) The electric field inside the wire. (b) The potential difference between two points separated 50 m along the wire. (c) The resistance of a copper wire with a length of 50 m. (d) The resistance at 0°C and 100°C , if the temperature coefficient of resistivity of copper is $\alpha = 0.00393 (\text{C}^\circ)^{-1}$.

4.- Two identical resistors are connected in series to a potential difference of V . Later on, the two resistors are connected in parallel to the same potential difference V . Which one of the two set-ups dissipates more power?

5.- An ammeter with resistance r_A is connected in series with a resistor, whose resistance R we want to measure, and a voltmeter is connected in parallel with the set, as can be seen in the figure. (a) Calculate R as a function of the values I_m and V_m measured by the ammeter and the voltmeter, respectively. (b) Calculate R when $V_m/I_m \gg r_A$. (c) If $V_m = 23 \text{ V}$, $I_m = 62 \text{ mA}$ and $r_A = 14 \Omega$, which is the value of R ?

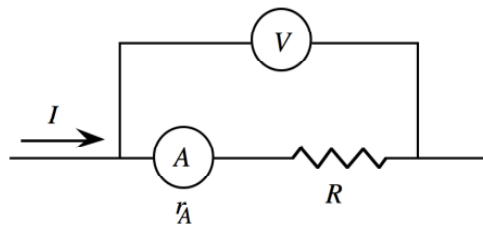

6.- A voltmeter with resistance r_V is connected in parallel with a resistor, whose resistance R we want to measure, and an ammeter is connected in series with the set, as can be seen in the figure. (a) Calculate R as a function of the values I_m and V_m measured by the ammeter and the voltmeter, respectively. (b) Calculate R when $V_m/I_m \ll r_V$. (c) If $V_m = 43 \text{ V}$, $I_m = 16 \text{ mA}$ and $r_V = 62 \text{ M}\Omega$, which is the value of R ?

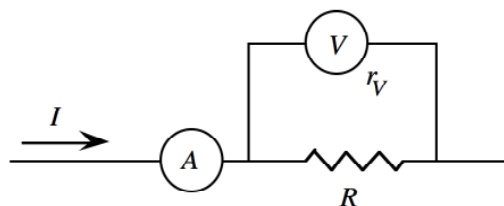

7.- *Dynamic resistance*, $R_{din} = dV/dI$, is a useful concept when non-ohmic circuit components are studied. For a diode, a simple model for the *pn* junction behaviour predicts a current-voltage relationship in the form $I(V) = I_0[\exp(eV/kT) - 1]$, where I_0 is the saturation current, different for each diode, k is the Boltzmann's constant, T is the absolute temperature and e is the electron charge. Obtain an expression for the dynamic resistance of this device.

BIBLIOGRAPHY

- H. D. Young, R. A. Freeman, “Física universitaria (Sears-Zemansky)” (vols. 1 y 2), Pearson Educación, México (2009).
- W. E. Gettys, F. J. Keller, M. J. Skove, “Física clásica y moderna”, McGraw-Hill, Madrid (1991). F. A. González, “La física en problemas”, Editorial Tébar-Flores, Madrid (1995).
- M. Alonso, E. J. Finn, “Física”, Addison-Wesley Iberoamericana, Wilmington (1995).
- S. Burbano, E. Burbano, “Problemas de física”, Librería General, Zaragoza (1980).
- V. Gandía, “Problemas de terminología”. Edita el autor, Valencia (1977).
- F. W. Sears, M. W. Zemansky, “Física general”, Editorial Aguilar, Madrid (1979).
- P. A. Tipler, G. Mosca, “Física para la ciencia y la tecnología” (vols. 1 y 2), Reverté, Barcelona (2009).
- C. Carnero, J. Aguiar, J. Carretero, “Problemas de física I. Mecánica”, Editorial Ágora, Málaga (1996).
- C. Carnero, J. Aguiar, J. Carretero, “Problemas de física II. Electromagnetismo”, Editorial Ágora, Málaga (1996).
- J. Llinares, A. Page, “Curso de física aplicada: electromagnetismo y semiconductores”, Servicio de Publicaciones, Universidad Politécnica de Valencia, Valencia (1987).
- L. Rosado, “Electrónica física y microelectrónica”, Paraninfo, Madrid (1987).